

Two-Degree-of-Freedom PID Temperature Controllers

TN Series

INSTRUCTION MANUAL

TCD210227AE	Autonics
-------------	-----------------

Thank you for choosing our Autonics product.

Read and understand the instruction manual and manual thoroughly before using the product.

For your safety, read and follow the below safety considerations before using.

For your safety, read and follow the considerations written in the instruction manual, other manuals and Autonics website.

Keep this instruction manual in a place where you can find easily.

The specifications, dimensions, etc are subject to change without notice for product improvement Some models may be discontinued without notice.

Follow Autonics website for the latest information.

Safety Considerations
<ul style="list-style-type: none">Observe all ‘Safety Considerations’ for safe and proper operation to avoid hazards. ⚠ symbol indicates caution due to special circumstances in which hazards may occur.
⚠ Warning Failure to follow instructions may result in serious injury or death

01. Fail-safe device must be installed when using the unit with machinery that may cause serious injury or substantial economic loss.(e.g. nuclear power control, medical equipment, ships, vehicles, railways, aircraft, combustion apparatus, safety equipment, crime/disaster prevention devices, etc.)

Failure to follow this instruction may result in personal injury, economic loss or fire.

02. Do not use the unit in the place where flammable/explosive/corrosive gas, high humidity, direct sunlight, radiant heat, vibration, impact or salinity may be present.

Failure to follow this instruction may result in explosion or fire.

03. Install on a device panel to use.

Failure to follow this instruction may result in electric shock.

04. Do not connect, repair, or inspect the unit while connected to a power source.

Failure to follow this instruction may result in fire or electric shock.

05. Check ‘Connections’ before wiring.

Failure to follow this instruction may result in fire.

06. Do not disassemble or modify the unit.

Failure to follow this instruction may result in fire or electric shock.

⚠ Caution Failure to follow instructions may result in injury or product damage

01. When connecting the power input and relay output, use AWG 20 (0.50 mm²) cable or over, and tighten the terminal screw with a tightening torque of 0.74 to 0.90 N m.

When connecting the sensor input and communication cable without dedicated cable, use AWG 28 to 16 cable and tighten the terminal screw with a tightening torque of 0.74 to 0.90 N m.

Failure to follow this instruction may result in fire or malfunction due to contact failure.

02. Use the unit within the rated specifications.

Failure to follow this instruction may result in fire or product damage

03. Use a dry cloth to clean the unit, and do not use water or organic solvent.

Failure to follow this instruction may result in fire or electric shock.

04. Keep the product away from metal chip, dust, and wire residue which flow into the unit.

Failure to follow this instruction may result in fire or product damage.

Cautions during Use

- Follow instructions in ‘Cautions during Use’. Otherwise, it may cause unexpected accidents.
- Check the polarity of the terminals before wiring the temperature sensor. For RTD temperature sensor, wire it as 3-wire type, using cables in same thickness and length. For thermocouple (TC) temperature sensor, use the designated compensation wire for extending wire.
- Keep away from high voltage lines or power lines to prevent inductive noise. In case installing power line and input signal line closely, use line filter or varistor at power line and shielded wire at input signal line. Do not use near the equipment which generates strong magnetic force or high frequency noise.
- Do not apply excessive power when connecting or disconnecting the connectors of the product.

- Install a power switch or circuit breaker in the easily accessible place for supplying or disconnecting the power.
- Do not use the unit for other purpose (e.g. voltmeter, ammeter), but temperature controller.
- When changing the input sensor, turn off the power first before changing. After changing the input sensor, modify the value of the corresponding parameter.
- Do not overlapping communication line and power line. Use twisted pair wire for communication line and connect ferrite bead at each end of line to reduce the effect of external noise.
- Make a required space around the unit for radiation of heat. For accurate temperature measurement, warm up the unit over 20 min after turning on the power.
- Make sure that power supply voltage reaches to the rated voltage within 2 sec after supplying power.
- Do not wire to terminals which are not used.
- This unit may be used in the following environments.
 - Indoors (in the environment condition rated in ‘Specifications’)
 - Altitude Max. 2,000 m
 - Pollution degree 2
 - Installation category II

Ordering Information
<p>This is only for reference, the actual product does not support all combinations. For selecting the specified model, follow the Autonics website .</p>
T N ① - ② 4 ③ ④ ⑤ - ⑥ S - ⑦

- ① Size**
S: DIN W 48 × H 48 mm
H: DIN W 48 × H 96 mm
L: DIN W 96 × H 96 mm
- ② Control method**
No mark: Fixed control
P: Program control
- ③ Alarm outputs**
2: Alarm 1 / 2
4: Alarm 1 / 2 / 3 / 4
6: Alarm 1 / 2 / 3 / 4 / 5 / 6
- ④ Control output 1**
R: Relay
S: SSR drive
C: Current or SSR drive

- ⑤ Control output 2**
R: Relay
S: SSR drive
C: Current or SSR drive

- ⑥ Communication**
N: None
R: RS485

⑦ Option input/output			
No.	Digital input	CT input	Transmission output
006	0	1	0
008	2	1	0
009	3	1	0
014	3	2	0
026	0	1	1
031	0	2	1
035	6	2	1

Manual

For proper use of the product, refer to the manuals and be sure to follow the safety considerations in the manuals.

Download the manuals from the Autonics website.

Software
<p>Download the installation file and the manuals from the Autonics website.</p> <p>■ DAQMaster DAQMaster is comprehensive device management program. It is available for parameter setting, monitoring.</p>

Product Components
<ul style="list-style-type: none">Product <ul style="list-style-type: none">Instruction manual Bracket

Sold Separately
<ul style="list-style-type: none">Communication converter: SCM Series <ul style="list-style-type: none">Current transformer (CT) Terminal protection cover <ul style="list-style-type: none">Front cover

Specifications	
Power supply	100 - 240 VAC~, 50/60 Hz ±10%
Power consumption	≤ 8 VA
Display type	11 segment, LCD type (operating value display part: 7 segment)
Sampling period	50 / 100 / 250 ms (parameter)
Input specification	Refer to ‘Input Type and Using Range’
Option input	CT <ul style="list-style-type: none">0.0-50.0 A (primary current measurement range) CT ratio: 1/1,000 Measurement accuracy: ±5% F.S. ±1digit
	Digital <ul style="list-style-type: none">Contact - ON: ≤ 2 kΩ, OFF: ≥ 90 kΩ Non contact - residual voltage ≤ 1.0 V, leakage current ≤ 0.1 mA Outflow current: ≈ 0.5 mA per input
Control output	Relay <ul style="list-style-type: none">250 VAC~ 3A 1a
	SSR <ul style="list-style-type: none">12 VDC= ±2 V, ≤ 20 mA
Option output	Alarm <ul style="list-style-type: none">250 VAC~ 3 A 1a
	Transmission <ul style="list-style-type: none">DC 4 - 20 mA (load resistance: ≤ 500 Ω, output accuracy: ±0.3% F.S.)
Option output	Communication <ul style="list-style-type: none">RS485
	Type <ul style="list-style-type: none">ON/OFF, P, PI, PD, PID
Control type	Multi SV <ul style="list-style-type: none">≤ 4 SV
	Group PID <ul style="list-style-type: none">≤ 8 group
	Zone PID <ul style="list-style-type: none">4 zones
	ARW (Anti Reset Windup) <ul style="list-style-type: none">50 to 200 %
Program control	Program <ul style="list-style-type: none">≤ 10 patterns
	Step <ul style="list-style-type: none">≤ 200 steps (1 pattern: ≤ 20 steps)
	Setting type <ul style="list-style-type: none">Time setting

Hysteresis	<ul style="list-style-type: none">Thermocouple, RTD: 1 to 100 (0.1 to 100.0) °C/°F Analog: 1 to 100 digit
Proportional band (P)	0.1 to 999.9 °C (0.1 to 999.9%)
Integral time (I)	0 to 9,999 sec
Derivative time (D)	0 to 9,999 sec
Control cycle (T)	<ul style="list-style-type: none">Relay / SSRP output: 0.1 to 120.0 sec Selectable current or SSR drive output: 1.0 to 120.0 sec
Manual reset	0.0 to 100.0%
Dielectric strength	Between the charging part and the case: 3,000 VAC~ 50/60 Hz for 1 min
Vibration	0.75 mm amplitude at frequency of 5 to 55 Hz (for 1 min) in each X, Y, Z direction for 2 hours
Relay life cycle	Mechanical <ul style="list-style-type: none">OUT1/2: ≥ 5,000,000 operations AL1/2/3/4/5/6: ≥ 20,000,000 operations
	Electrical <ul style="list-style-type: none">OUT1/2: ≥ 200,000 operations AL1/2/3/4/5/6: ≥ 100,000 operations
Insulation resistance	≥ 100 MΩ (500 VDC= megger)
Insulation type	Double insulation or reinforced insulation (mark: ☒, dielectric strength between the measuring input part and the power part: 3 kV)
Noise immunity	±2 kV square shaped noise by noise simulator (pulse width: 1 μs) R-phase, S-phase
Memory retention	≈ 10 years (non-volatile semiconductor memory type)
Ambient temperature	-10 to 50 °C, storage: -20 to 60 °C (no freezing or condensation)
Ambient humidity	35 to 85%RH
Protection structure	IP65 (Front panel, IEC standards)
Loader port	<ul style="list-style-type: none">TNS: top side TNH, TNL: front side
Accessory	Bracket
Unit weight (packaged)	<ul style="list-style-type: none">TNS: ≈ 128 g (≈ 156 g) TNH: ≈ 184 g (≈ 286 g) TNL: ≈ 301 g (≈ 443 g)
Approval	CE VDE UL

Communication Interface	
■ RS485	
Comm. protocol	Modbus RTU/ASCII, Sync-Master, PLC ladderless
Connection type	RS-485, RS-422A
Application standard	EIA RS485 compliance with
Maximum connection	32 units (address: 01 to 99)
Synchronous method	Asynchronous
Comm. Method	Two-wire half duplex
Comm. effective range	≤ 800 m
Comm. speed	≤ 115,200 bps
Response time	5 to 99 ms (default: 20 ms)
Start bit	1 bit (fixed)
Data bit	8 bit (fixed)
Parity bit	None (default), Odd, Even
Stop bit	1 bit, 2 bit (default)
EEPROM life cycle	≈ 1,000,000 operations (Erase / Write)

• 1 character of ModBus RTU is fixed at 11 bit.

Input Type and Using Range					
The setting range of some parameters is limited when using the decimal point display.					
Input type	Decimal point	Display	Using range (°C)	Using range (°F)	
Thermo-couple	K (CA)	1	<i># C RH</i>	-200 to 1,350	-328 to 2,463
		0.1	<i># C RL</i>	-199.9 to 999.9	-199.9 to 999.9
	J (IC)	1	<i>J C H</i>	-200 to 800	-328 to 1,472
		0.1	<i>J C L</i>	-199.9 to 800.0	-199.9 to 999.9
	E (CR)	1	<i>E C RH</i>	-200 to 800	-328 to 1,472
		0.1	<i>E C RL</i>	-199.9 to 800.0	-199.9 to 999.9
	T (CC)	1	<i>E C C H</i>	-200 to 400	-328 to 752
		0.1	<i>E C C L</i>	-199.9 to 400.0	-199.9 to 752.0
	B (PR)	1	<i>b P P</i>	0 to 1,800	32 to 3,272
		1	<i>P P P</i>	0 to 1,750	32 to 3,182
	S (PR)	1	<i>S P P</i>	0 to 1,750	32 to 3,182
		1	<i>N NN</i>	-200 to 1,300	-328 to 2,372
	N (NN)	1	<i>C t t</i>	0 to 2,300	32 to 4,172
		1	<i>G t t</i>	0 to 2,300	32 to 4,172
L (IC)	1	<i>L C H</i>	-200 to 900	-328 to 1,652	
	0.1	<i>L C L</i>	-199.9 to 900.0	-199.9 to 999.9	
L (RUS)	1	<i>L R H</i>	-200 to 800	-328 to 1,472	
	0.1	<i>L R L</i>	-199.9 to 800.0	-199.9 to 999.9	
U (CC)	1	<i>U C H</i>	-200 to 400	-328 to 752	
	0.1	<i>U C L</i>	-199.9 to 400.0	-199.9 to 752.0	
RTD	Platinel II	1	<i>P L I I</i>	0 to 1,390	32 to 2,534
	Cu50 Ω	0.1	<i>C U 5</i>	-199.9 to 200.0	-199.9 to 392.0
		0.1	<i>C U 10</i>	-199.9 to 200.0	-199.9 to 999.9
	JPt100 Ω	1	<i>J P t H</i>	-200 to 650	-328 to 1,202
		0.1	<i>J P t L</i>	-199.9 to 650.0	-199.9 to 999.9
	DPt50 Ω	0.1	<i>d P t 5</i>	-199.9 to 600.0	-199.9 to 999.9
1		<i>d P t H</i>	-200 to 650	-328 to 1,202	
DPt100 Ω	0.1	<i>d P t L</i>	-199.9 to 650.0	-199.9 to 999.9	
	1	<i>N I t 2</i>	-80 to 200	-112 to 392	
Analog	0 to 10 V	-	<i>A V 1</i>	0 to 10 V	
	0 to 5 V	-	<i>A V 2</i>	0 to 5 V	
	1 to 5 V	-	<i>A V 3</i>	1 to 5 V	
	0 to 100 mV	-	<i>A M V I</i>	0 to 100 mV	
	0 to 20 mA	-	<i>A M A I</i>	0 to 20 mA	
	4 to 20 mA	-	<i>A M A 2</i>	4 to 20 mA	

• Permissible line resistance per line: ≤ 5 Ω

01) C (TT): Same as existing W5 (TT) type sensor

02) G (TT): Same as existing W (TT) type sensor

■ Display accuracy		
Input type	Using temperature	Display accuracy
Thermo-couple RTD	At room temperature (23°C ±5°C)	(PV ±0.2% or ±1 °C higher one) ±1-digit <ul style="list-style-type: none">Thermocouple K, J, T, N, E below -100 °C and L, U, PLII, RTD Cu50 Ω, DPt50 Ω: (PV ±0.3% or ±2 °C higher one) ±1-digit Thermocouple C, G and R, S below 200 °C: (PV ±0.3% or ±3 °C higher one) ±1-digit Thermocouple B below 400 °C: There is no accuracy standards
	Out of room temperature range	(PV ±0.5% or ±2 °C higher one) ±1-digit <ul style="list-style-type: none">RTD Cu50 Ω, DPt50 Ω: (PV ±0.5% or ±3 °C higher one) ±1-digit Thermocouple R, S, B, C, G: (PV ±0.5% or ±5 °C higher one) ±1-digit Other sensors: ≤ ±5 °C (≤-100 °C)
Analog	At room temperature (23°C ±5°C)	±0.2% F.S. ±1-digit
	Out of room temperature range	±0.5% F.S. ±1-digit

Unit Descriptions

- Below is based on TNL Series.
- The shape and function of each part may be different depending on the series, and it is possible to check the additional information in the user manual.

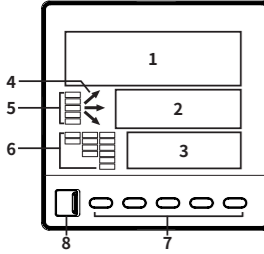

- PV display part (White)**
 - RUN mode: Displays PV (Present value) and unit.
 - Setting mode: Displays parameter name
- SV display part (Green)**
 - RUN mode: Displays SV (Setting value) and unit.
 - Setting mode: Displays parameter setting value.
- Operating value display part (Yellow)**
 - RUN mode: Displays selected value among MV (Manipulated output value), CT, TIME with unit.
- Temperature control indicator**
 - Fixed control: Relative PV value status display based on SV
 - PV > SV (↗), PV = SV (→), PV < SV (↘)
 - Program control: Displays temperature control status of up (↗), hold (→), down (↘).

5. Operation status indicator

Display	Name	Description
LOCK	Lock	Turns ON during key lock status.
PROG	Program	Turns ON during program control.
WAIT	Wait	Turns ON during waiting status.
HBA1/2	Heater break alarm	Turns ON when the heater break alarm output is ON.

7. Input key

Display	Name	Description
[U]	User key	
[M]	Mode key	
[◀], [▶], [▲], [▼]	Setting value control key	

8. PC loader port

For connecting communication converter (SCM-USP).

6. Output status indicator

Display	Name	Description
OUT1/2	Control output	Turns ON when the control output is ON
AT	Auto tuning	Flashes during auto tuning every 1 sec
MAN	Manual control	Turns ON during manual control mode
STOP	Control output stop	Turns ON during control output stop mode
HOLD	Program control hold	Turns ON when program control is hold status
AL1 to 6	Alarm output	Turns ON when the alarm output is ON

Errors

Display	Input	Description	Output	Troubleshooting
oPEN	Temperature sensor	Flashes at 0.5 sec interval when input sensor is disconnected or sensor is not connected.	'Sensor error, MV' parameter setting value	Check input sensor status.
	Analog	Flashes at 0.5 sec interval when input is over F.S. ±10%.	'Sensor error, MV' parameter setting value	Check analog input status.
HHHH	Temperature sensor	Flashes at 0.5 sec interval if the input value is above the input range.	Heating: 0%, Cooling: 100%	When input is within the rated input range, this display disappears.
	Analog	Flashes at 0.5 sec interval if the input value is over 5 to 10% of high limit or low limit value.	Normal output	
LLLL	Temperature sensor	Flashes at 0.5 sec. interval if the input value is below the input range.	Heating: 100%, Cooling: 0%	
	Analog	Flashes at 0.5 sec interval if the input value is over 5 to 10% of low limit or high limit value.	Normal output	
ERR	-	Flashes at 0.5 sec interval if there is error for setting and it returns to the error-before screen.	-	Check setting method.

Dimensions

- Unit: mm, For the detailed drawings, follow the Autonics website.
- Below is based on TNS Series.

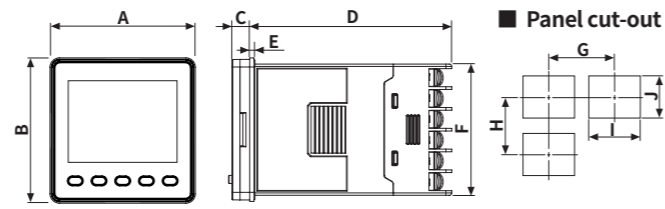

	Body						Panel cut-out			
	A	B	C	D	E	F	G	H	I	J
TNS	49	49	6	69	1.5	44.8	≥ 65	≥ 65	45 ^{+0.6} ₀	45 ^{+0.6} ₀
TNH	49	97	6	69	1.5	91.5	≥ 65	≥ 115	45 ^{+0.6} ₀	92 ^{+0.8} ₀
TNL	97	97	6	69	1.5	91.5	≥ 115	≥ 115	92 ^{+0.8} ₀	92 ^{+0.8} ₀

■ Bracket

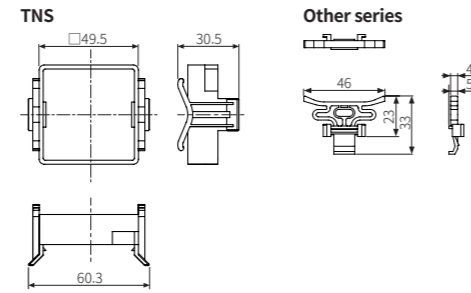

Installation Method

■ TNS

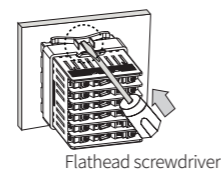

Flathead screwdriver

■ Other series

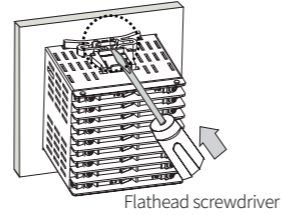

Flathead screwdriver

Insert the unit into a panel, fasten the bracket by pushing with tools with a flathead screwdriver.

Connections

- Digital input is not electrically insulated from internal circuits, so it should be insulated when connecting other circuits.

■ TNS

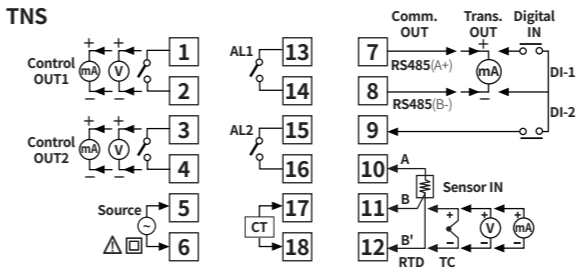

■ TNH

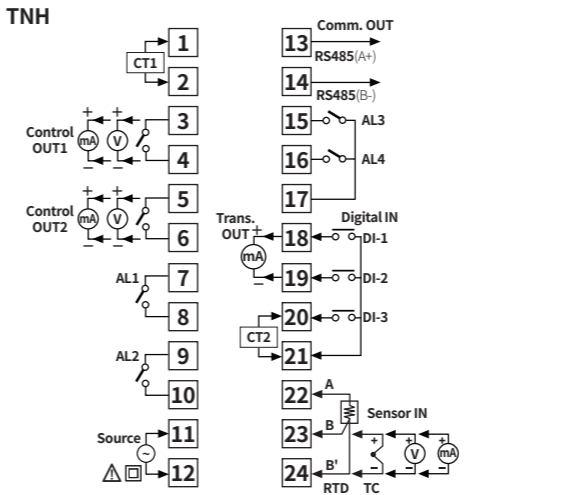

■ TNL

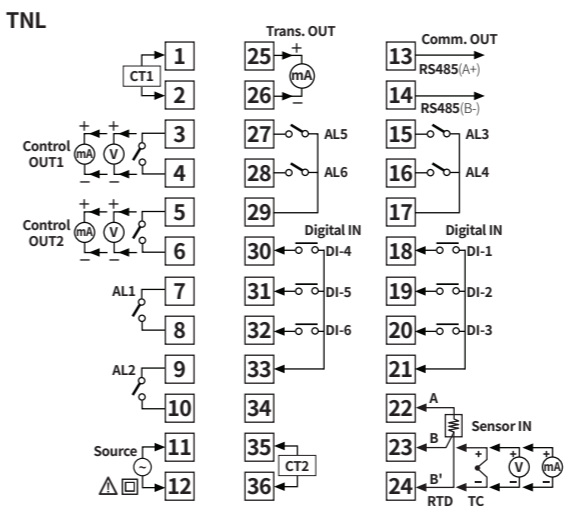

Crimp Terminal Specifications

- Unit: mm, Use the crimp terminal of follow shape.

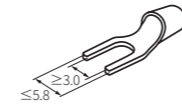

Fork crimp terminal

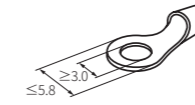

Round crimp terminal

Initial Display When Power is ON

When power is supplied, after all display will flash for 1 sec, model name is displayed sequentially. After input sensor type will flash twice, enter into RUN mode.

Display part	1. Model	2. Model	3. Input specification	4. RUN mode
PV	EN5P	R5	TYPE	oPEN
SV	42RR	006	CRH	0

Mode Setting

Operation	Mode	Parameter	Value
Auto before entering to mode (when using password)	Password input	Password	Key input
		Pass	Auto
		Fail	[MODE]
[◀], [▲], [▼] (in manual control)	MV setting	Enter mode	Selected mode
[◀], [▲], [▼] (in auto control)	SV setting	Change value: [◀], [▶]	Password input
[▼] + [▲] 3 sec	Control output run/stop	Save: [MODE] or no key input over 3 sec	
[M] + [▲]	Operating value display part (MV/CT/TIME) setting		
[U] + [◀] / [▶] / [▲] 2 sec	Shortcut key 1/2/3		
[◀] + [▼] 3 sec	Key lock		[◀] + [▼] 3 sec
[M] 2 sec	Parameter group		[◀] 2 sec
[U] 2 sec	User customized parameter group		[U]
[◀] + [▲] + [▼] 5 sec	Parameter reset		Auto

* TNS series does not support 'MV setting', 'Operation value display part setting' mode. For the details, refer to the user manual.